

3 – FACING THE BOTTOM-BRACKET SHELL

ABOUT THIS CHAPTER

This chapter is about a milling procedure (called *facing*) that is done to bottom-bracket shells. Facing the bottom-bracket shell improves the alignment of the bearing parts that are installed in the bottom-bracket shell. Improving the alignment of the bearing parts improves the quality of the adjustment and the longevity of the parts.

After the **GENERAL INFORMATION** section, there are separate sections for using three different types of bottom-bracket shell facing tool systems. These sections are:

PARK BTS-1 FACING PROCEDURE
MODIFIED VAR 3802/2/C FACING PROCEDURE
PARK BFS-1 & CAMPAGNOLO 725 FACING PROCEDURE

GENERAL INFORMATION

TERMINOLOGY

Facing: To cut the end of a cylinder (the bottom-bracket shell in this case) so that it is flat and precisely perpendicular to the axis of the cylinder.

Facer: The cutter that is used to do facing. The facer may also be called a facing mill.

Bottom-bracket shell: The part of the frame that houses the bearings that the crank arms rotate around.

Pilot: A part of a bottom-bracket facer that is used to align the facer so that it will cut precisely perpendicular to the axis of the bottom-bracket-shell threads. The pilot consists of the pilot shaft and the pilot hole.

INDICATIONS

Symptoms indicating need of facing

There is only one symptom that indicates the need for facing the bottom-bracket shell. When attempting to adjust a high-quality adjustable-cup bottom bracket with new parts, the spindle feels smooth through a portion of its rotation and tight in another portion of its rotation. This is called a tight/loose pattern. The tight/loose pattern can also be caused by conditions other than a bottom-bracket shell that needs facing, such as: low precision parts, worn out parts, bent spindles, and cross-threaded cups. Under these conditions, the tight/loose pattern is due to poor quality of manufacturing, not abuse or wear.

Other reasons for facing the bottom-bracket shell

When tapping a bottom-bracket shell (particularly with a Park BTS-1) it is a simple matter to go a step further and face the bottom bracket as well. This is cheap insurance to enable easy adjustment of the bottom bracket and maximize the longevity of bottom-bracket parts. For this reason, some shops will routinely tap and face bottom-bracket shells on high-end bikes.

In the case that a shop sells bare framesets, it is a good marketing technique to face them before putting them out for display. Knowledgeable customers will look for whether facing has been done to evaluate whether the frame has been properly prepped for assembly.

Cartridge-bearing bottom brackets

When a cartridge-bearing bottom bracket has bearings mounted in cups with flanges or lockrings that bear against the ends of the bottom-bracket shell, facing the bottom-bracket shell is just as important as with cup and cone type bottom brackets.

Some cartridge-bearing bottom brackets are an enclosed unit. The bearings and spindle are inseparable, and the bearings are inside a cylinder. This type might be held in the bottom-bracket shell by two mounting rings, or one end of the unit might be threaded, and the other end is secured by a separate mounting ring. With this enclosed-

3 – FACING THE BOTTOM BRACKET SHELL

unit type of cartridge-bearing bottom bracket, an out-of-face shell will not affect the bearing and spindle alignment. If this is the case, then there is no value to facing the bottom-bracket shell.

TOOL CHOICES

The thread type of the bottom-bracket shell is what determines what tool you will need. The following list (table 3-1, below) covers all tools for the job. The preferred choices are in **bold**. A tool is preferred because of a balance among: ease of use, quality, versatility, and economy.

TIME AND DIFFICULTY

Facing a bottom bracket is a job of little difficulty. With tapping already done it should take an additional 10–15 minutes.

COMPLICATIONS

Titanium

Titanium has completely different metallurgical characteristics than steel or aluminum. It is necessary for a facer to be designed in a dramatically different way to be suitable for facing titanium. Once designed to be suitable for titanium, a facing tool will no longer be suitable for other materials. Special facers for titanium are not available at the time of this writing; if they do ever become available, whether enough titanium frames will be encountered that need facing is a significant question.

Aluminum

Aluminum is a perfectly suitable material for facing, but presents some special concerns to the mechanic. *The type of cutting oil used is critical.* There are cutting oils made specifically for use on aluminum on the container. Any cutting oil that is suitable will specify for use on aluminum on the container. Words like “all-purpose” and “multi-purpose” should not be interpreted to mean including aluminum.

Chrome plating

Chrome-plated bottom brackets cannot be faced unless the chrome is first removed, a potentially difficult procedure. A file or grinding stone can be used for chrome removal.

Failure of Campagnolo threaded inserts to install fully

Campagnolo threaded inserts are the female pilot of the facing tool. Their design creates several problems. These threaded inserts must be installed so that they are completely inside the bottom-bracket shell. The insertion of threaded inserts requires at least 17mm of thread length on both sides of the bottom-bracket shell, whereas few cups require more than 13mm of thread depth; consequently, many bottom-bracket shells do not have enough thread length to use the Campagnolo 725 facing tool. Adding threads is a difficult procedure and hard on the taps.

The threaded inserts are also very fat and interfere with anything that protrudes into the bottom-bracket shell, such as fasteners for bottom-bracket cable guides and excess tubing length on lugged frames.

BOTTOM-BRACKET-FACING TOOLS (table 3-1)

Tool	Fits and considerations
Campagnolo 725	Piloted handles w/ 1.37" x 24tpi BSC/ISO inserts, very expensive.
Campagnolo 724I	Italian 36mm x 24tpi inserts for 725.
Campagnolo 724F	French 35mm x 1mm inserts for 725.
Campagnolo 730	Spanners used for installing 725 inserts.
Park BFS-1	Heavy duty facing tool made for frame manufacturers to shorten shells (can be used with its own BSC threaded guides or any Park taps as guides).
Park BTS-1	Same tool as bottom-bracket tap, faces 1.37" x 24tpi shells, excellent quality and convenience.
Park 693	36mm x 24tpi taps needed to use BTS-1 to face Italian shells.
Park 694	35mm x 1mm taps needed to use BTS-1 to face French shells.
VAR 380/2/C	Same as tap set, can be modified to use as a facer with addition of VAR 37DL2 and United Bicycle Tool 37B.
VAR 37DL2	Used with VAR 380/2/C tap set to convert to a facer.
United Bicycle Tool 37B	Used with VAR 380/2/C tap set to convert to a facer.
VAR 380/3/C	Facer set uses unthreaded pilots, low precision.

3- FACING THE BOTTOM BRACKET SHELL

Facing-tool chatter

Facing-tool chatter is the tendency of the facing tool to bite and jump at rapid frequency. This tendency leaves a series of radial lines in the face of the bottom-bracket shell. These radial lines are a cosmetic flaw, not a mechanical flaw. To some degree the chatter marks are preventable, but circumstances outside the control of the mechanic make make chatter marks unavoidable at times. Proper facing technique can reduce the likelihood of chatter occurring, but if the type and hardness of the bottom-bracket shell material is not compatible with the design of the facing tool, then chatter cannot be prevented. In the facing procedures there are detailed instructions of the technique that reduces the likelihood of chatter occurring. See figure 3.1 below.

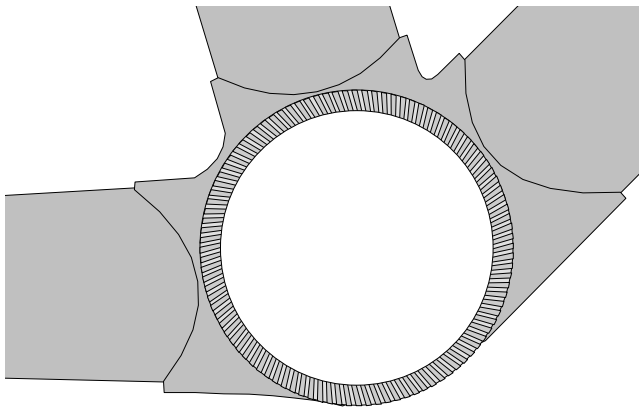

3.1 *The radial lines in the face of this shell are the result of chatter.*

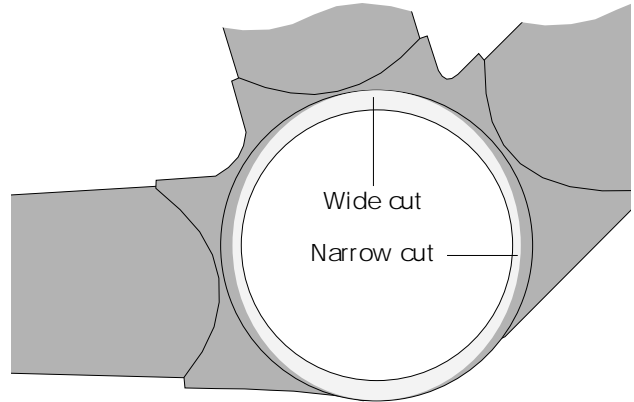
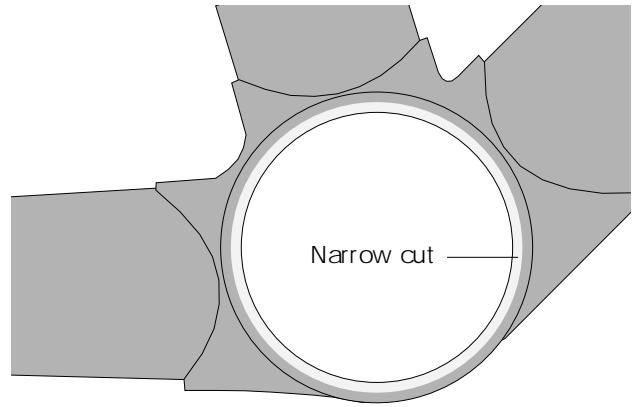

3.2 *As long as the facing cut is a full 360°, it does not matter if the cut is narrow, or not a uniform width. Both the shell faces shown here are acceptably faced.*

Uniform width of cut

When facing a bottom-bracket shell, the objective is to complete a cut that is a full 360° around the face of the shell. Sometimes, once the 360° cut is achieved, the cut is not a uniform width; in fact, the cut may be very narrow at points, and not near as wide as the shell face. There is a tendency to conclude that more facing is needed when this occurs. It is not a mechanical necessity to achieve a uniform, full-width cut; the only reason to attempt to create a uniform, full-width cut is to improve the cosmetics. It may take several extra minutes of work to achieve a cosmetically-superior facing cut. If the appearance of the cut can be substantially improved by working 1–2 extra minutes, fine; otherwise, leave the cut with a non-uniform width, as long as it is a full 360°. See figure 3.2 (below and in left column).

3 - FACING THE BOTTOM BRACKET SHELL

CARE OF FACING TOOLS

Facing tools are very expensive and easily damaged. Proper cutting technique is important to get good life from them, but that is not all. When storing facers, make sure they are clean and coated with oil. The cutting edges are easily chipped by light impact with other metal objects, so handle and store them in a way that this kind of accidental contact will not happen. On hooks on a peg-board is a good way to store facing tools.

When cleaning facing tools use a brush and solvent. Blowing them clean with compressed air is not damaging to the facer but is dangerous. Coat the cutter with a light oil after cleaning and drying.

Using a facer on chrome-plated bottom-bracket shells will dull it quickly, and is almost impossible to do. The facer will fail to get a bite on a chrome-plated bottom-bracket shell at normal pressure. In some cases a chrome-plated bottom-bracket shell can be faced by using very high cutting pressure, but facing chrome-plated bottom-bracket shells is strongly advised against; *tool damage is likely!*

PARK BTS-1 FACING PROCEDURE

If the shell face is clean raw metal, it can be difficult to track facing progress. In this case, use a material called machinist's dykem (available from general tool supply stores or machinist's supply stores) to paint the shell face before proceeding. Handle dykem carefully, as it can stain almost anything.

1. [] **Complete *BOTTOM-BRACKET-TAPPING PROCEDURE* (page 2-3) through step 13 before proceeding.**

The Park BTS-1 uses the taps as the pilot hole for the pilot shaft of the facing tool. If the taps are left protruding from the ends of the shell then the facer will cut against them instead of against the end of the shell. The taps have a very short length, so it is unlikely once the taps are all the way into the existing thread that they will need to go in further to be recessed in the shell.

2. [] **If either or both taps are protruding from end of shell, continue tapping procedure until each tap is recessed in end of shell.**

Park BTS-1 tap handles are not retained in the taps by a threaded device, but by internal spring clips. Just pull out firmly on a handle and it will leave the tap behind.

3. [] **Withdraw one tap handle.**

4. [] **Place facer on withdrawn handle and insert handle back into taps.**

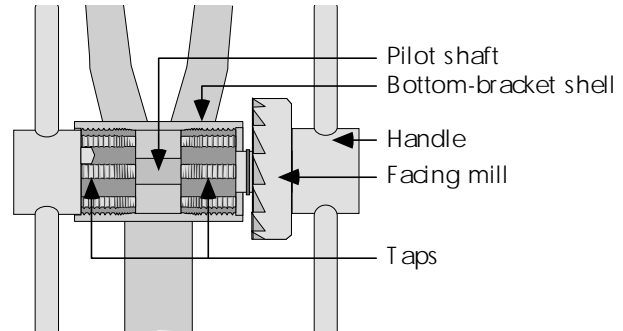

3.3 *Cut-away view of a bottom-bracket shell with a Park BTS-1 facing tool in place.*

Cutting oil needs to be added in the next step to assure the ease and quality of the cut, as well as to preserve the sharpness of the tool.

5. [] **Add generous amount of appropriate type of cutting oil to facer teeth.**

A very important part of the remaining steps is that the facer should be turned clockwise *only*. Unlike taps, the design of facer teeth causes them to dull easily if rotated counterclockwise.

It is also important to use correct pressure and speed, as little pressure is required to get a sharp tool to cut. Pressing in with one hand at the center of the tool is generally enough pressure. There is very little leverage needed to face, so there is no reason to turn the handles with both hands. A slow steady speed should be adequate.

Fine modulations of the cutting pressure and slower cutting speed should be used to prevent or reduce a phenomenon called *chatter*. Chatter is the tendency of the tool to bite and jump at a rapid frequency, resulting in a chattering feeling and noise from the tool as it cuts. For every metal there is an optimum pressure; try reducing or increasing the pressure to eliminate chatter. If chattering occurs it will leave a series of radial lines in the face of

3- FACING THE BOTTOM BRACKET SHELL

the bottom-bracket shell, which is a cosmetic flaw, not a mechanical one (see figure 3.1). Chatter cannot always be prevented, but it can be minimized by modulating the cutting pressure and speed. In addition to pressure and speed being factors, the design of the facer teeth has to be suitable to the particular hardness of metal being cut. When the design of the facer teeth is too aggressive for the hardness of the metal being cut, then some chatter is inevitable and must be lived with.

6. [] **Rotate facer *clockwise only* at moderate pressure and speed for approximately four full revolutions.**

In the next step, the progress of the facing is inspected. A partially faced bottom bracket will have freshly cut metal only for a portion of the 360° shell face. It is no concern whether the width of the cut is uniform, only whether there is freshly cut metal for a full 360°. If it is not a full circle, proceed to step #8.

7. [] **Pull facer away from end of shell and inspect progress of cut.**

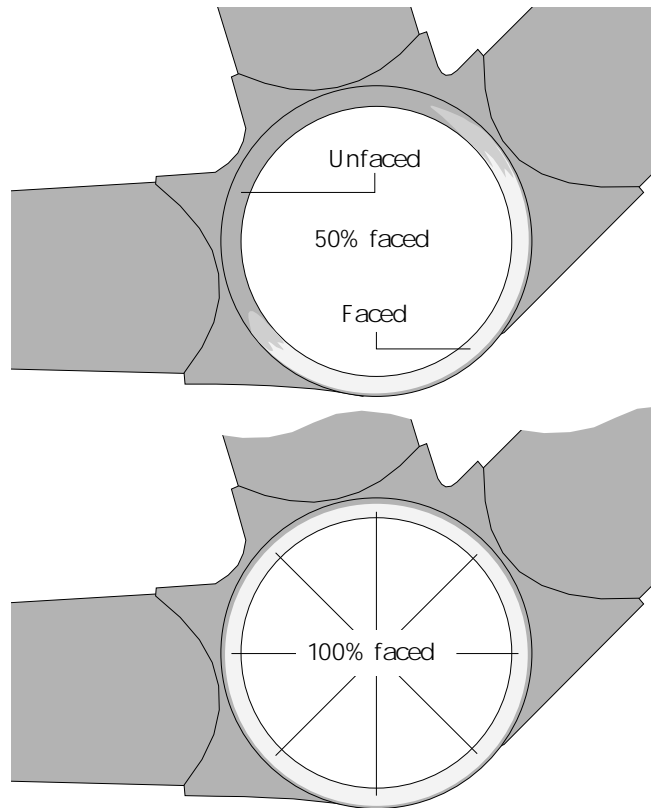

3.4 The cut needs to be a full 360° to be complete. Uniform width of cut is meaningless.

8. [] **If more facing is needed, repeat steps 5–7.**

Under the pressure needed to cut metal, the facer can leave burrs when it stops. The next step is to spin the facer one more revolution under very light pressure to knock off any burrs.

9. [] **When first side is adequately faced, use facer for one more revolution under very light pressure.**
10. [] **Pull both handles out and reinstall each handle on opposite side.**
11. [] **Repeat steps 5–8 for second side until second side is adequately faced.**
12. [] **When second side is adequately faced, use facer for one more revolution under very light pressure.**

3 – FACING THE BOTTOM BRACKET SHELL

13. [] Remove handle that has facer mounted and remove facer.
14. [] Put handle back into taps and shell.
15. [] Turn both tap handles until taps are almost fully out and are evenly protruding from shell.
16. [] Rotate both handles simultaneously enough to be sure that both taps are fully unthreaded, then withdraw both taps at same time.
17. [] Clean bottom-bracket threads with toothbrush and solvent.
18. [] Clean outside of bottom-bracket shell and rest of frame as necessary.
19. [] Clean bottom-bracket taps and facer.
20. [] Use appropriate procedures/worksheets to install bottom bracket and crank arms as necessary.

MODIFIED VAR 380/ 2/C FACING PROCEDURE

The VAR 380/2/C piloted bottom-bracket taps can be converted into an economical and effective facing tool. One handle is converted into a facing tool, while the other tap handle and tap is left inside the bottom-bracket shell to act as a pilot mechanism. The conversion requires a VAR 37DL2 facer and a spacer made and sold by United Bicycle Tool called the 37B. The spacer is needed because the 37DL2 is shorter than the tap that is being replaced when modifying.

If the shell face is clean raw metal, it can be difficult to track facing progress. In this case, use a material called machinist's dykem (available from general tool supply stores or machinist's supply stores) to paint the shell face before proceeding. Handle dykem carefully, as it can stain almost anything.

1. [] Complete **BOTTOM-BRACKET-TAPPING PROCEDURE** (page 2-3) through step 13 before proceeding.
2. [] Unthread one tap and handle from the shell.
3. [] Unthread retaining nut from handle and remove tap from handle.

To convert the tap handle to a facer the tap is removed, the facer is installed, a spacer is installed, and the retaining nut is installed. In some cases the peg on the tap handle is too long to fit in the hole in the backside of the facer and needs to be filed shorter. This has no effect on using the handle for a tap later. The spacer is not symmetrical and must be installed correctly. *The end of the spacer*

with the reduced diameter goes against the facer. If the spacer is put on backwards then the retaining nut will not engage the handle thread fully.

4. [] Place 37DL2 facer and spacer on withdrawn handle, secure retaining nut, and insert handle back into remaining tap and handle already in shell.

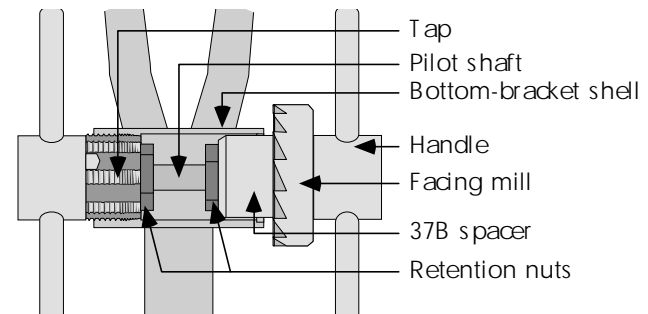

3.5 Cut-away view of a bottom-bracket shell with a modified VAR 380/2/C facing tool in place.

Cutting oil needs to be added in the next step to assure the ease and quality of the cut, as well as to preserve the sharpness of the tool.

5. [] Add generous amount of appropriate type of cutting oil to facer teeth.

A very important part of the remaining steps is that the facer should be turned clockwise *only*. Unlike taps, the design of facer teeth causes them to dull easily if rotated counterclockwise.

It is also important to use correct pressure and speed, as little pressure is required to get a sharp tool to cut. Pressing in with one hand at the center of the tool is generally enough pressure. There is very little leverage needed to face, so there is no reason to turn the handles with both hands. A slow steady speed should be adequate.

Fine modulations of the cutting pressure and lower cutting speed should be used to prevent or reduce a phenomenon called *chatter*. Chatter is the tendency of the tool to bite and jump at a rapid frequency, resulting in a chattering feeling and noise from the tool as it cuts. For every metal there is an optimum pressure; try reducing or increasing the pressure to eliminate chatter. If chattering occurs it will leave a series of radial lines in the face of the bottom-bracket shell, which is a cosmetic flaw, not a mechanical one (see figure 3.1). Chatter cannot always be prevented, but it can be minimized by modulating the cutting pressure and speed. In addition to pressure and speed being factors, the design of the facer teeth has to be suitable to the particular hardness of metal being cut.

3- FACING THE BOTTOM BRACKET SHELL

When the design of the facer teeth is too aggressive for the hardness of the metal being cut, then some chatter is inevitable and must be lived with.

6. [] **Rotate facer *clockwise only* at moderate pressure and speed for approximately four full revolutions.**

In the next step, the progress of the facing is inspected. A partially faced bottom bracket will have freshly cut metal only for a portion of the 360° shell face. It is no concern whether the width of the cut is uniform, only whether there is freshly cut metal for a full 360°. If it is not a full circle, proceed on to step #8.

7. [] **Pull facer away from end of shell and inspect progress of cut.**

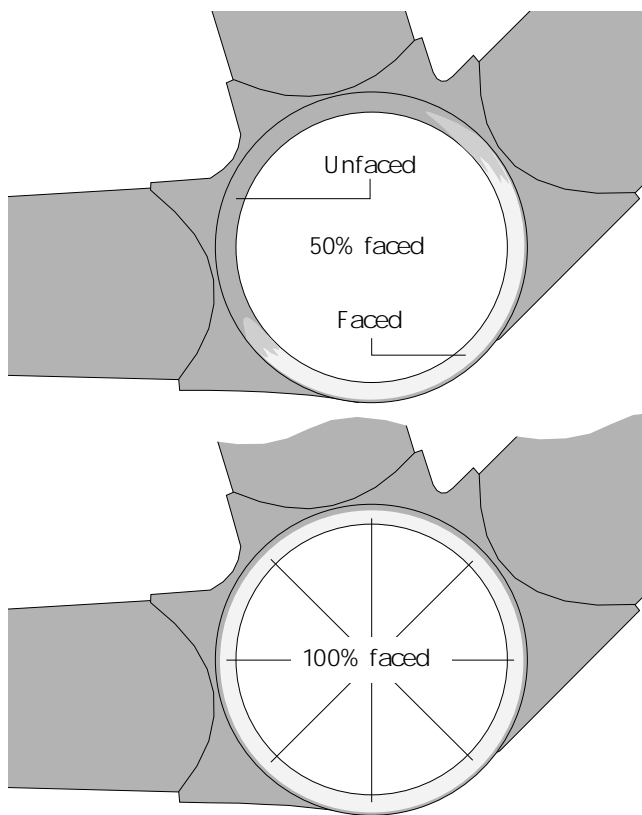

3.6 The cut needs to be a full 360° to be complete. Uniform width of cut is meaningless.

8. [] **If more facing is needed, repeat steps 5–8.**

Under the pressure needed to cut metal, the facer can leave burrs when it stops. The next step is to spin the facer one more revolution under very light pressure to knock off any burrs.

9. [] **When first side is adequately faced, use facer for one more revolution under very light pressure.**
10. [] **Remove handle with facer and remove retaining nut, spacer, and facer.**

In the next two steps the handle that was used as a facer is converted back into a tap and installed in the bottom-bracket shell *before the other tap is removed*. This prevents a tap from cross-threading on the way out due to lack of piloting.

11. [] **Install and secure tap back on handle.**
12. [] **Thread tap back into shell fully.**
13. [] **Remove other tap and handle from shell.**
14. [] **Convert removed handle into facer, same as in step 4.**
15. [] **Repeat steps 5–8 for second side until second side is adequately faced.**
16. [] **When second side is adequately faced, use facer for one more revolution under very light pressure.**
17. [] **Remove handle that has facer mounted and remove facer.**

In the next two steps the facer is converted back to a tap and put back in the shell *before the other tap is removed from the shell*. This prevents a tap from cross-threading on the way out due to lack of piloting.

18. [] **Convert handle that was facer back to a tap.**
19. [] **Thread tap 1–2 full turns into shell.**
20. [] **Back other tap out of shell until both taps are equally outside of shell.**
21. [] **Rotate both handles simultaneously enough to be sure that both taps are fully unthreaded, then withdraw both taps at same time.**
22. [] **Clean bottom-bracket threads with toothbrush and solvent.**
23. [] **Clean outside of bottom-bracket shell and rest of frame as necessary.**
24. [] **Clean bottom-bracket taps and facer.**
25. [] **Use appropriate procedures/worksheets to install bottom bracket and crank arms as necessary.**

PARK BFS-1 & CAMPAGNOLO 725 FACING PROCEDURE

The Park BFS-1 and Campagnolo 725 facers are identical tools except for one thing: the Park BFS-1 utilizes the taps as guides, and the Campagnolo 725 uses special threaded guides that are not taps. The difference in use is that when using Park BFS-1 taps to tap the bottom-

3 – FACING THE BOTTOM BRACKET SHELL

bracket-shell threads, the taps are left in the shell to provide the pilot hole. Installing and removing the threaded guides that the Campagnolo 725 uses is an additional step.

If the shell face has clean raw metal, it can be difficult to track facing progress. In this case, use a material called machinist's dykem (available from general tool supply stores or machinist's supply stores) to paint the shell face before proceeding. Handle dykem carefully, as it can stain almost anything.

1. [] **If using Park BTS-1 for tapping, complete BOTTOM-BRACKET-TAPPING PROCEDURE (page 2-3) through step 13 before proceeding; otherwise, complete the entire tapping procedure.**
2. [] **Thread appropriate thread guides into shell until both are recessed into shell and securely fixed.**
3. [] **If either or both guides are protruding from end of shell remove guides and continue tapping procedure until each guide is able to recess in end of shell.**
4. [] **Insert facer in either side and assemble tension device (large pressure washer, small lockwasher, spring, and tension nut) if desired.**

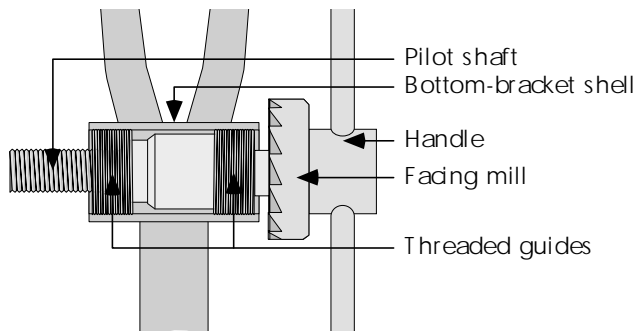

3.7 Cut-away view of a bottom-bracket shell with a Campagnolo 725 facer in place.

Cutting oil needs to be added in the next step to improve the ease and quality of the cut, as well as to preserve the sharpness of the tool.

5. [] **Add generous amount of appropriate type of cutting oil to facer teeth.**

A very important part of the remaining steps is that the facer should be turned clockwise *only*. Unlike taps, the design of facer teeth causes them to dull easily if rotated counterclockwise.

It is also important to use correct pressure and speed, as little pressure is required to get a sharp tool to cut. Pressing in with one hand at the center of the tool is generally enough pressure. There is very little leverage needed to face, so there is no reason to turn the handles with both hands. A slow steady speed should be adequate.

Fine modulations of the cutting pressure and lower cutting speed should be used to prevent or reduce a phenomenon called *chatter*. Chatter is the tendency of the tool to bite and jump at a rapid frequency, resulting in a chattering feeling and noise from the tool as it cuts. For every metal there is an optimum pressure; try reducing or increasing the pressure to eliminate chatter. If chattering occurs it will leave a series of radial lines in the face of the bottom-bracket shell, which is a cosmetic flaw, not a mechanical one (see figure 3.1). Chatter cannot always be prevented, but it can be minimized by modulating the cutting pressure and speed. In addition to pressure and speed being factors, the design of the facer teeth has to be suitable to the particular hardness of metal being cut. When the design of the facer teeth is too aggressive for the hardness of the metal being cut, then some chatter is inevitable and must be lived with.

It is difficult to modulate the pressure responsively when using these tools' tensioning device. Hand pressure should be adequate unless the facer is dull.

6. [] **Rotate facer clockwise only at moderate pressure and speed for approximately four full revolutions.**

In the next step, the progress of the facing is inspected. A partially faced bottom bracket will have freshly cut metal only for a portion of the 360° shell face. It is no concern whether the width of the cut is uniform, only whether there is freshly cut metal for a full 360°. If the cut metal is not a full circle, proceed to step #8.

3- FACING THE BOTTOM BRACKET SHELL

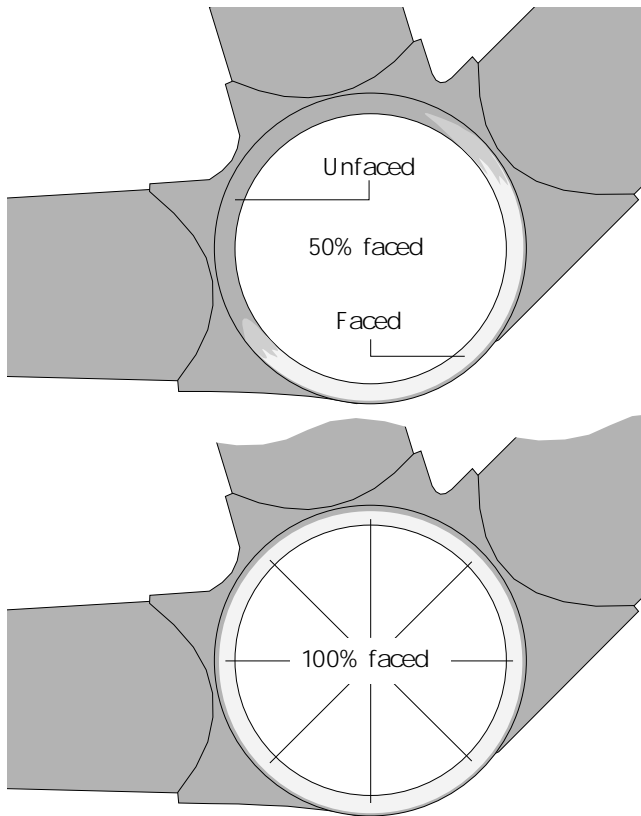

3.8 *The cut needs to be a full 360° to be complete. Uniform width of cut is meaningless.*

If the tension device is engaged and not set too tightly, it should be possible to pull the facer away from the shell without un-setting the tension. If the tension device is not being used, then just slide the facer out of the shell to inspect the cutting progress.

7. [] Pull facer away from end of shell and inspect progress of cut.

8. [] If more facing is needed, repeat steps 5–8.

Under the pressure needed to cut metal, the facer can leave burrs when it stops. The next step is to spin the facer one more revolution under very light pressure to knock off any burrs.

9. [] When first side is adequately faced, use facer for one more revolution under very light pressure.

10. [] Remove tension device (if used) and pull facer out of pilot hole.

11. [] Repeat steps 5–8 for second side until second side is adequately faced.

12. [] When second side is adequately faced, use facer for one more revolution under very light pressure.

13. [] Remove tension device (if used) and pull facer out of pilot hole.

There are two choices in the next step. Choosing the correct one determines which of the following steps need to be done. The choice is based on whether the pilot system being used up to this point had threaded guides, or whether the Park BTS-1 taps were left in place after tapping.

3 - FACING THE BOTTOM BRACKET SHELL